

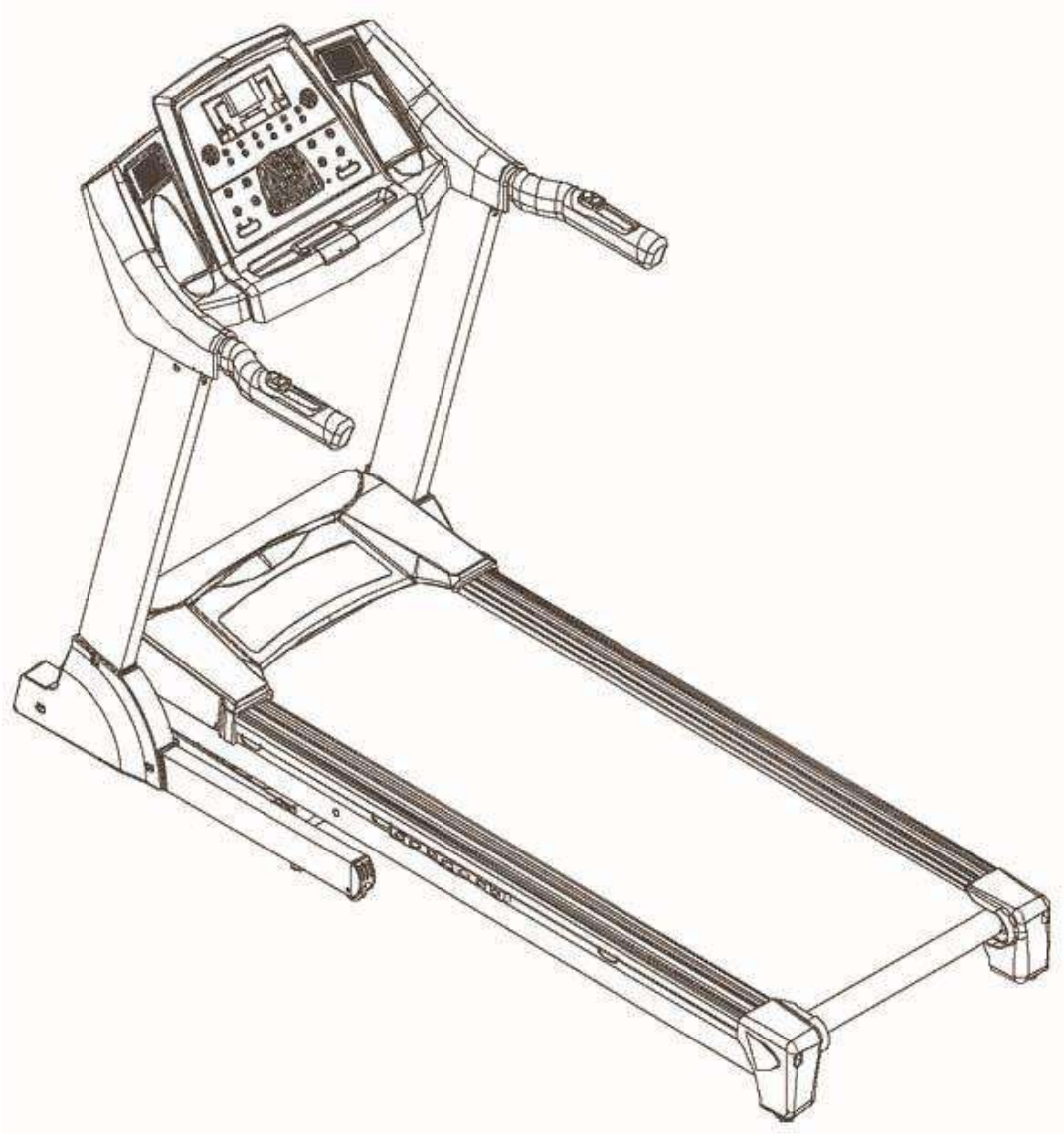

## ACCESS OWNER'S MANUAL



Product may vary slightly from the item pictured due to model upgrades.

Read all instructions carefully before using this product. Retain this owner's manual for future reference.

*This is a high-power item; please DO NOT use the same outlet with other-high power household appliances. Please choose an outlet exclusively for the machine and ensure the fuse is 10A.*

# TABLE OF CONTENTS

1.	IMPORTANT SAFETY INSTRUCTIONS_____	3
2.	IMPORTANT ELECTRICAL INFORMATION_____	4
3.	IMPORTANT OPERATING INSTRUCTIONS_____	5
4.	ASSEMBLY INSTRUCTIONS_____	6
5.	FOLDING INSTRUCTIONS_____	10
6.	GROUNDING METHODS_____	11
7.	OPERATION GUIDE_____	12
8.	EXERCISE GUIDE_____	20
9.	MAINTENANCE INSTRUCTIONS_____	22
10.	EXPLODED DIAGRAM_____	26
11.	PARTS LIST_____	27
12.	TROUBLE SHOOTING GUIDE_____	30
13.	WARRANTY_____	32

# 1. IMPORTANT SAFETY INSTRUCTIONS

**WARNING** - Read all instructions before using this treadmill.

It is important your treadmill receives regular maintenance to prolong its useful life. Failing to regularly maintain your treadmill may void your warranty.

**Danger** – To reduce the risk of electric shock disconnect your treadmill from the electrical outlet prior to cleaning and/or service work.

DO NOT USE AN EXTENSION CORD: DO NOT ATTEMPT TO DISABLE THE GROUNDED PLUG BY USING IMPROPER ADAPTERS OR IN ANY WAY MODIFY THE CORD SET.

- Install the treadmill on a flat level surface with access to a 220-240 volt (50/60Hz), grounded outlet.
- Do not operate treadmill on deeply padded, plush or shag carpet. Damage to both carpet and treadmill may result.
- Do not block the rear of the treadmill. Provide a minimum of 1 metre clearance between the rear of the treadmill and any fixed object.
- Place your unit on a solid, level surface when in use
- Never allow children on or near the treadmill.
- When running, make sure the plastic clip is fastened on your clothing. It is for your safety, should you fall or move too far back on the treadmill.
- Keep hands away from all moving parts.
- Never operate the treadmill if it has a damaged cord or plug.
- Keep the cord away from heated surfaces.
- Do not operate where aerosol spray products are being used or where oxygen is being administered. Sparks from the motor may ignite a highly gaseous environment.
- Never drop or insert any object into any openings.
- The treadmill is intended for in-home use only and not suitable for long time running.

- To disconnect, turn all controls to the off position, remove the safety key, and then remove the plug from the outlet.
- The pulse sensors are not medical devices. Various factors, including the user's movement, may affect the accuracy of heart rate readings. The pulse sensors are intended only as exercise aids in determining heart rate trends in general.
- Use the handrails provided; they are for your safety.
- Wear proper shoes. High heels, dress shoes, sandals or bare feet are not suitable for use on your treadmill. Quality athletic shoes are recommended to avoid leg fatigue.
- Allowed temperature: 5 to 40 degrees.

Remove the safety key after use to prevent unauthorized treadmill operation.

## 2. IMPORTANT ELECTRICAL INFORMATION

### WARNING!

- NEVER use a ground fault circuit interrupt (GFCI) wall outlet with this treadmill. Route the power cord away from any moving part of the treadmill including the elevation mechanism and transport wheels.
- NEVER remove any cover without first disconnecting AC power.
- NEVER expose this treadmill to rain or moisture. This treadmill is not designed for use outdoors, near a pool, or in any other high humidity environment.

### 3. IMPORTANT OPERATING INSTRUCTIONS

- Be sure to read the entire manual before operating your machine.
- Understand that changes in speed and incline do not occur immediately. Set your desired speed on the computer console and release the adjustment key. The computer will obey the command gradually.
- Use caution while participating in other activities while walking on your treadmill, such as watching television, reading, etc. These distractions may cause you to lose balance or stray from walking in the centre of the belt; which may result in serious injury.
- In order to prevent losing balance and suffering unexpected injury, **NEVER** mount or dismount the treadmill while the belt is moving. This unit starts with at a very low speed. Simply standing on the belt during slow acceleration is proper after you have learned to operate this machine.
- Always hold on to handrail while making control changes.
- A safety key is provided with this machine. Remove the safety key will stop the walking belt immediately; the treadmill will shut off automatically. Inserting the safety key will reset the display.
- Do not use excessive pressure on console control keys. They are precision set to function properly with little finger pressure.

## 4. ASSEMBLY INSTRUCTIONS

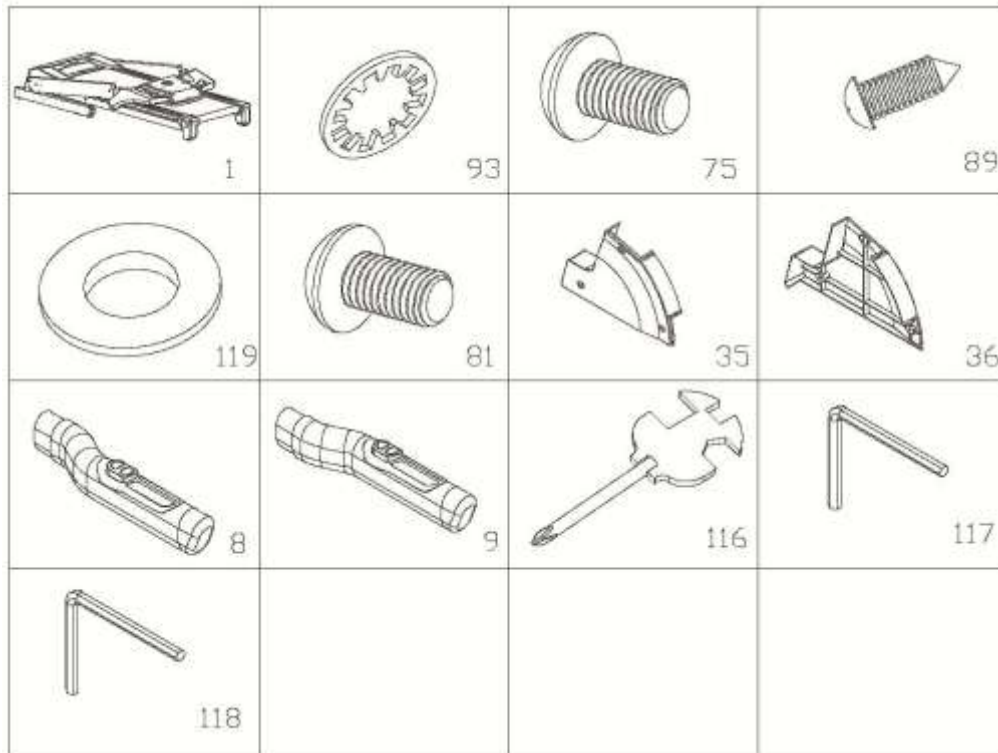

### PART LIST

NO.	Description	Specification	Qty.	NO.	Description	Specification	Qty.
1	Main Frame		1	81	Bolt	M8*15	4
93	Lock Washer	10	10	35	Left Upright Tube Cover		1
75	Bolt	M10*12	10	36	Right Upright Tube Cover		1
89	Screw	ST4.2*12	6	117	5# Allen Wrench	5mm	1
119	Arc Washer	8	4	118	6# Allen Wrench	6mm	1
8	Left Handle Bar		1	9	Right Handle Bar		1
116	Wrench w/screw Driver	S=13、14、15	1				

### STEP 1:

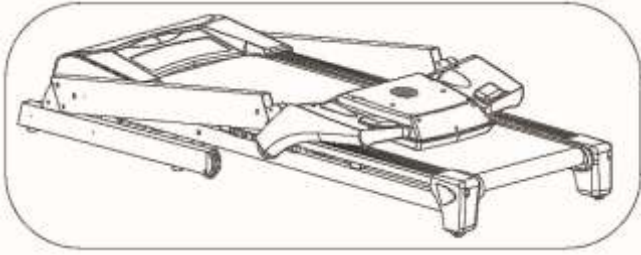

1. Open the carton
2. Extract the parts listed above
3. Place the Main Frame (1) onto level ground

**STEP 2:**

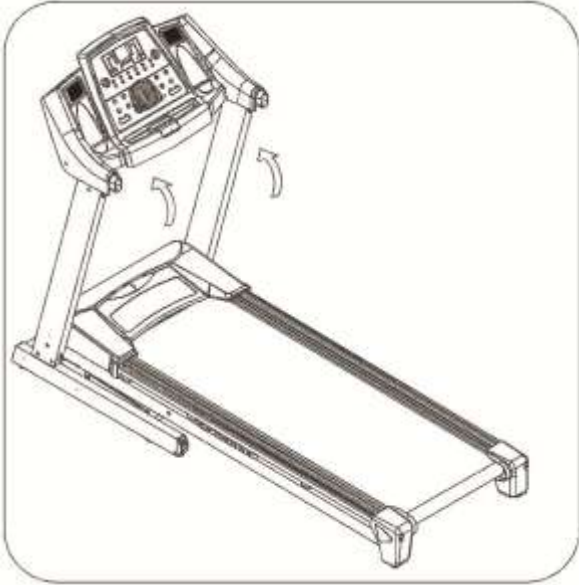

1. Raise the Computer and Upright tubes in the direction of the arrows.

*Note: Whilst erecting the uprights, make sure the upright does not press against and damage the wires inside the upright tubes. Keep holding the upright and computer by hand so they do not fall down and cause injury*

**STEP 3:**

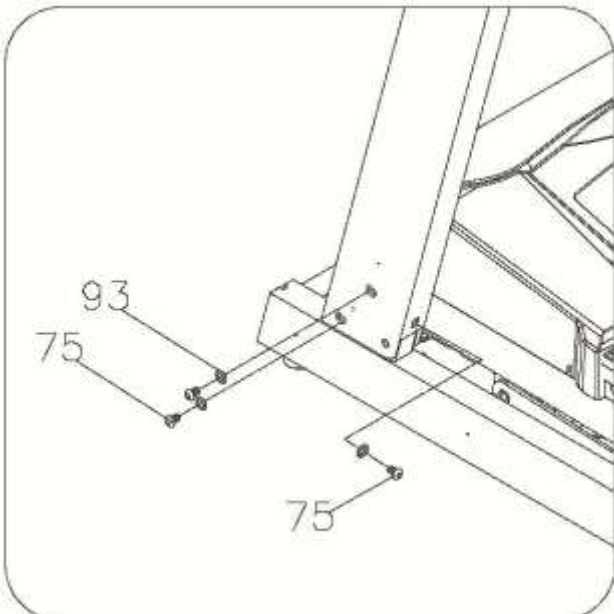

1. Using the 6# Allen Wrench, screw the Bolt (75) M10\*12 through the Lock Washer (93 )
2. Then lock the Left Upright Tube onto the Main Frame

*Note: Support the Left Upright Tube with your hands to prevent it falling down and causing injury.*

**STEP 4:**

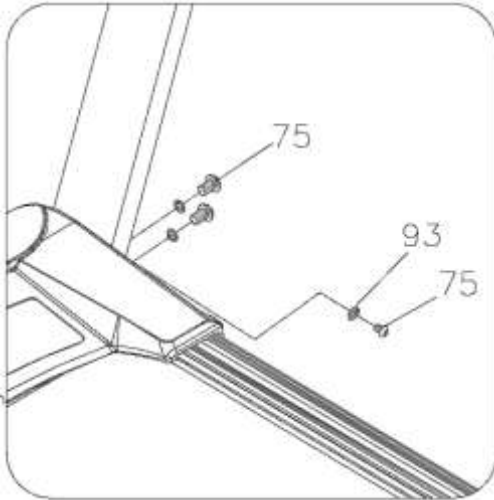

1. Using the 5# Allen Wrench, screw the Bolt (75) M10\*12 through the Lock Washer (93 )
2. Then lock the Right Upright Tube onto the Main Frame

**STEP 5:**

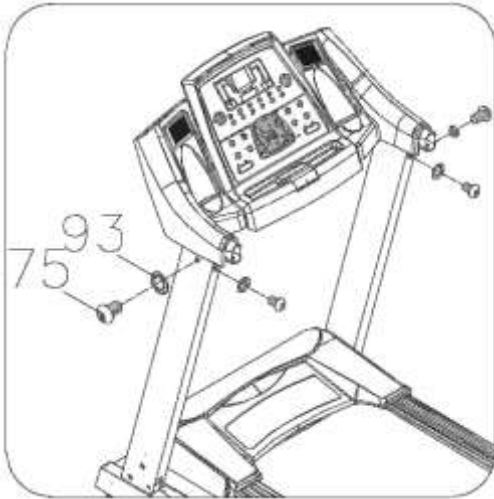

1. Using the 5# Allen Wrench, screw the Bolt (75) M10\*12 through the Lock Washer (93 )
2. Lock the Computer into the Main Frame

**STEP 6:**

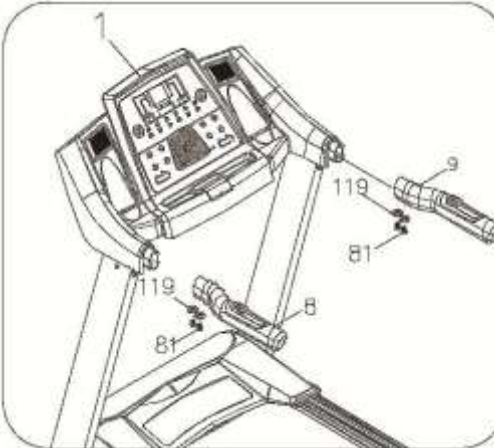

1. Using the 5# Allen Wrench, screw the Bolt ( 81) M8\*15 through the Arc Washer (119)
2. Lock the Left and Right Handle bar onto the Computer

**STEP 6:**



1. Lock the Left and Right Upright Tube  
Cover onto the Base Frame with Screw  
(89) ST4.2\*12

## 5. FOLDING INSTRUCTIONS

### Folding:

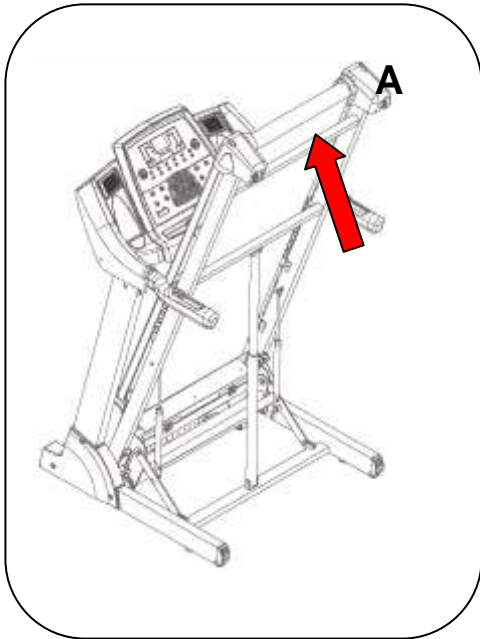

Place your hand on position (A), then pull up the base frame until you hear the click sound emitted when the air pressure bar (10) is locked into the round tube.

### Unfolding:

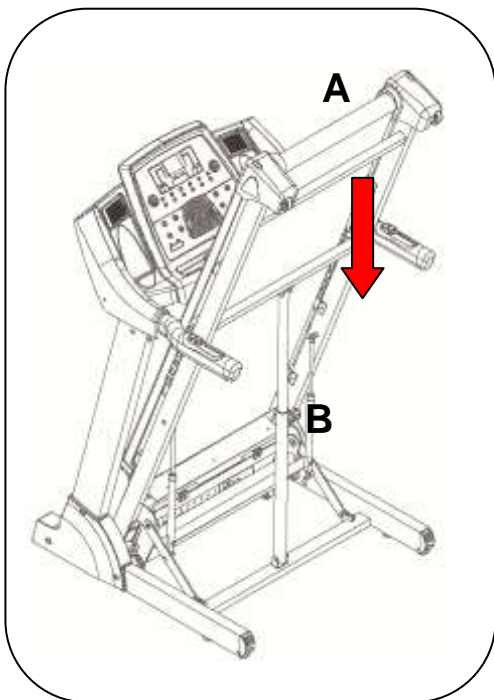

1. Whilst supporting position (A) with your hand, pull out the spring knob (B) with your right hand.
2. Maintain this pin position whilst gently pulling the base frame towards the ground. Let the base frame descend slowly to the ground.
3. The base frame will descend automatically. (Please keep people and any pets away the machine during descent)

## 6. GROUNDING METHODS

This product must be grounded. In the event of malfunction or breakdown, grounding reduces the risk of electric shock. This product is equipped with a cord with an equipment-grounding conductor and a grounding plug. The plug must be plugged into an appropriate outlet that is properly installed and grounded in accordance with all local codes and ordinances.

### **DANGER**

Improper connection of the equipment-grounding conductor can result in risk of electric shock.

Check with a qualified electrician or serviceman if you are in doubt as to whether the product is properly grounded.

Do not modify the plug provided with the product – if it will not fit the outlet; have a proper outlet installed by a qualified electrician.

This product is for use on a nominal 240-volt circuit and has a grounding plug that looks like the plug illustrated in denoted by (A) in following figure. Ensure the product is connected to an outlet having the same configuration as the plug. No adapter should be used with this product.

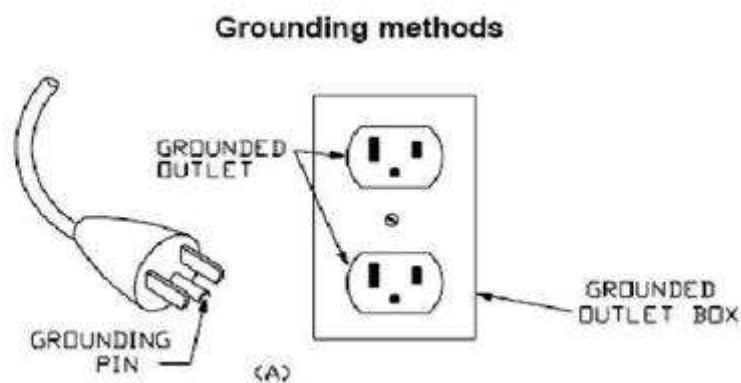

# 7. OPERATION GUIDE



## 1. Window display:

“Incline” window:	Displays incline gradient
“Speed” window:	<p>Displays the speed range from 1.0 – 22 km/h.</p> <p>When applying settings to the machine, it will show the inner program and body fat test FAT</p>
“Pulse/Cal” window:	<p>Displays calorie data. It will count from 0 – 999, after exceeding 999 it will restart from 0. During countdown, it will count from the setting data to 0, upon reaching 0, the machine will stop smoothly and display ‘End ’</p> <p>When testing pulse by holding the sensors with two hands, the window will show the pulse data and the light will show. The pulse data range is 50-200 beats/min</p> <p>(Pulse data is for reference ONLY and cannot be used as medical data)</p>

“Time” window:	Displays time, it will count from 0:00 to 99:59
“Distance” window:	Displays distance, it will count from 0.00 to 99.9km

## 2. Button functions:

- “Program” button: Press this button to select the program. The different settings are: “0:00”, “P1-P24”, “U1-U3”, “FAT” totaling 28 programs. Manual mode is the default program, the default speed is 1.0 km/h. (“0:00” is manual program, P1-P24 are preset programs, U1-U3 are self-defined programs, FAT is the body fat test function)
- “Mode” button: Press this button to select the mode. The different settings are: “0:00”, “15:00”, “1.0”, “50”. (“0:00” is manual mode, “15:00” is timer countdown mode, “1.0” is distance countdown mode, “50” is calories countdown mode). When setting each mode, you can press speed +/- and incline +/- to set the data, press “START” to start the machine.
- “Start” button: After connecting the power and attaching the safety key attached, press this button at any time to start the machine. If started from the manual mode, the machine will run at the lowest speed, 1.0 km/h, and incline 0.
- “Stop” button: When the machine is running, pressing this button will stop the machine at any time and all the data will be reset.
- “Speed +”, “Speed –” button: Data can be entered using these buttons. When the machine is running, press the button to adjust the speed. Each press adjusts the speed by 0.1km/h. Holding a speed button over 0.5 seconds will continually increase or decrease the speed by 0.1km/h intervals.
- “Incline +”, “Incline –” button: When the machine is running, press the button to adjust incline. Incline changes at 1 interval per press. Holding the button for over 0.5 seconds, will increase or decrease incline continually.

“Incline: 3,6,9,12,15,18”                      Incline shortcut button to set incline quickly

“Speed:3,6,9,12,15,18”                      Speed shortcut button to set speed quickly



Fan function button:                      Turns fan on and off

MP3 on / off button:                      Turns speakers on and off

### 3. Quick Start (manual)

1. Turn on power via power switch; attach the safety key to the computer.
2. Press START button, the system will enter a three second countdown, the buzzer will sound and the time window display the countdown. The speed will run at 1.0km/h after 3 seconds.
3. After start-up, you can use “SPEED+” and “SPEED -” to adjust the speed; use “INCLINE+”、  
“INCLINE -” to adjust the incline.

### 4. Manual Mode:

1. If you do not enter any settings and press the START button directly, the treadmill will start to run from speed 1.0km/h and incline 0. The other windows will start to count in a positive direction, press “SPEED+” and “SPEED-” adjust speed, press “INCLINE+” and “INCLINE -” to adjust incline.
2. To setup time, press the “MODE” button to enter into timer countdown. The TIME window will display “15:00” and flash. Press “SPEED+”, “SPEED-”, “INCLINE+”, “INCLINE -” to set desired time. The setting range is 5:00-99:00.
3. To setup distance, press the “MODE” button to enter into distance countdown. The DISTANCE window will display “1.0” and flash. Press “SPEED+”, “SPEED-”, “INCLINE+”, “INCLINE -” to set desired distance. The setting range is 0.5—99.9.
4. To setup calories, press the “MODE” button to enter into calories countdown. The CALORIE window will display “50” and flash. Press “SPEED+”, “SPEED-”, “INCLINE+”, “INCLINE -” to set desired calories. The setting range is 10-999.

- After applying settings, press “START” button to begin, the treadmill will run after 3 seconds, press “SPEED+”, “SPEED-”, “INCLINE+”, “INCLINE –” to adjust the speed and the incline. Pressing STOP will stop the treadmill.

## 5. Preset programs:

- Press “PROGRAM” button and DIST window will display and cycle through programs 1 to 24 (P1-P24) allowing you to choose the desired program.
- Set the total program time using “SPEED+”, “SPEED-”, “INCLINE+”, “INCLINE –”. The flashing TIME window will initially display the advance setting time at 10:00.
- Press “START” button to start the preset program. All programs are divided into 10 sections. The time for each section is 1/10<sup>th</sup> of the total program time. When the system enters into the next section, the treadmill will emit 3 “beeps” and the speed will be changed according to the program settings.
- Press “SPEED+”, “SPEED-”, “INCLINE+”, “INCLINE –” to change the SPEED and INCLINE during the program. When the program enters the next section it will return to the settings of the following section of the preset program after emitting 3 “beeps”.

### Program exercise chart

Each program is divided into 10 sections for the exercise time and each time section has the speed and incline listed accordingly.

Time	Program	TIME INTERVAL									
		1	2	3	4	5	6	7	8	9	10
P1	SPEED	2	4	3	4	3	5	4	2	5	3
	INCLINE	1	2	3	3	1	2	2	3	2	2
P2	SPEED	2	5	4	6	4	6	4	2	4	2
	INCLINE	1	2	3	3	2	2	3	4	2	2
P3	SPEED	2	5	4	5	4	5	4	2	3	2
	INCLINE	1	2	2	3	1	2	2	2	2	1
P4	SPEED	3	6	7	5	8	5	9	6	4	3
	INCLINE	2	2	3	3	2	2	4	6	2	2
P5	SPEED	3	6	7	5	8	6	7	6	4	3
	INCLINE	1	2	4	3	2	2	4	5	2	1
P6	SPEED	2	8	6	4	5	9	7	5	4	3
	INCLINE	2	2	6	2	3	4	2	2	2	1
P7	SPEED	2	6	7	4	4	7	4	2	4	2
	INCLINE	4	5	6	6	9	9	10	12	6	3
P8	SPEED	2	4	6	8	7	8	6	2	3	2
	INCLINE	3	5	4	4	3	4	4	3	3	2
P9	SPEED	2	4	5	5	6	5	6	3	3	2
	INCLINE	3	5	3	4	2	3	4	2	3	2

P10	SPEED	2	3	5	3	3	5	3	6	3	3
	INCLINE	4	4	3	6	7	8	8	6	3	3
P11	SPEED	2	5	8	10	6	9	5	3	2	2
	INCLINE	1	3	5	8	10	7	6	3	2	3
P12	SPEED	2	5	5	4	4	6	4	2	3	4
	INCLINE	3	5	6	7	12	9	11	11	6	3
P13	SPEED	2	7	4	7	8	9	4	5	3	2
	INCLINE	5	6	6	4	6	5	8	9	4	2
P14	SPEED	2	6	5	4	8	6	5	2	3	3
	INCLINE	5	6	5	8	4	5	5	10	6	3
P15	SPEED	2	6	5	4	8	7	5	3	3	2
	INCLINE	3	4	5	6	3	5	5	6	4	3
P16	SPEED	2	5	7	5	8	6	5	2	4	2
	INCLINE	1	5	6	8	12	9	10	9	5	3
P17	SPEED	2	5	6	7	8	9	10	5	3	4
	INCLINE	3	5	6	8	6	5	8	7	5	3
P18	SPEED	2	3	5	6	8	6	9	6	5	2
	INCLINE	5	7	5	8	6	5	9	10	6	2
P19	SPEED	3	7	6	5	9	7	6	3	5	2
	INCLINE	3	5	6	8	5	6	5	12	8	3
P20	SPEED	3	7	9	10	11	12	10	8	5	2
	INCLINE	2	5	6	7	6	5	8	6	3	2
P21	SPEED	3	6	8	7	9	10	5	8	3	2
	INCLINE	3	6	8	9	9	6	8	10	6	3
P22	SPEED	3	5	8	6	9	10	8	12	6	3
	INCLINE	2	6	8	10	12	10	12	8	5	2
P23	SPEED	3	5	9	11	12	8	6	5	3	2
	INCLINE	2	6	8	10	9	7	8	10	6	3
P24	SPEED	3	8	10	11	12	10	10	8	5	3
	INCLINE	3	6	8	9	10	12	9	6	3	2

## 6. Self defined programs:

There are 3 user self-defined programs: U1, U2, and U3.

### 1. User self-defined program setting:

Cycle through the programs by pressing the “PROGRAM” button continually until U1, U2, or U3 is reached. The “time” window will then flash glitter and show the time 15:00.

Press “INCLINE+”, “INCLINE-”, “SPEED+”, “SPEED-” to set the total running time.

Press “mode” to set program data. To set the first interval speed, press “speed+”, “speed-” or use the speed shortcut buttons. To set first interval incline press “incline+”, “incline-” or use incline shortcut buttons. The total time for each of the 10 individual intervals is 1/10<sup>th</sup> of the total program time.

Press “mode” button to finish the first interval time and enter into the second interval time.

Repeat until all 10 intervals have been completed. These settings will remain in the machine even after it is turned off.

### 2. User self-defined program start-up:

When the machine is waiting for operation, cycle through the programs by pressing the “PROGRAM” button continually until U1, U2, or U3 is reached. Then press start to begin selected program.

## Program parameters and ranges

	Initial	Initial Data	Set Range	Display Range
TIME(MIN:SECOND)	0:00	15:00	5:00-99:00	0:00 - 99:59
INCLINE(SECTION)	0	0	0-20	0-20
SPEED(K/h)	1.0	1.0	1.0-22	1.0-22
DISTANCE(KM)	0	1.0	0.5-99.9	0.00 - 99.9
PULSE(hypo/min)	P	N/A	N/A	50-200
CALORIE(THERM)	0	50	10-999	0 - 999

**7. BODY FAT TESTER:**

Cycle through the programs by pressing the “PROGRAM” button continually until “FAT” – the body fat tester is reached. Press “MODE” enter in data for F-1, F-2, F-3, F-4, F-5 (F-1 SEX, F-2 AGE, F-3 HEIGHT, F-4 WEIGHT, F-5 FAT TESTER).

Press “SPEED+”, “SPEED -” to enter in data for F-1, F-2, F-3 and F-4. (Refer to the following chart)

Press “MODE” to set F-5, grasp the hand pulse, the window will display your body quality index after 3 seconds. The body quality index is to test the relation between height and weight. The body FAT allows any male and female to adjust their weight with the body quality index.

F-1	Sex	01 male	02 female
F-2	Age	10-----99	
F-3	Height	100----200	
F-4	Weight	20-----150	
F-5	FAT	≤19	Underweight
	FAT	=(20---25)	Normal weight
	FAT	=(25---29)	Overweight
	FAT	≥30	Obese

## **8. Safety function:**

If the safety key is pulled off the window will display "SAFEKEY", the treadmill will emit a beeping sound, at this time machine cannot operate. After replacing the safety key the LCD window show the weight set up by last time, equipment reset, wait for enter command.

## **9. Sleep function:**

When treadmill stopped, it will enter sleep function if no commands are entered within 10 minutes. Press the power key to wake the console and resume operation.

## **10. MP3 function:**

When the treadmill is turned on connect external mp3 devices. Volume can be controlled using the external device.

## 8. EXERCISE GUIDE

**PLEASE NOTE:** Before beginning any exercise program, consult your physician. This is important especially if you are over the age of 45 or individuals with pre-existing health problems.

The pulse sensors are not medical devices. Various factors, including the user's movement, may affect the accuracy of heart rate readings. The pulse sensors are intended only as an exercise aid in determining heart rate trends in general.

Exercising is great way to control your weight, improving your fitness and reduce the effect of aging and stress. The key to success is to make exercise a regular and enjoyable part of your everyday life.

The condition of your heart and lungs and how efficient they are in delivering oxygen via your blood to your muscles is an important factor to your fitness. Your muscles use this oxygen to provide enough energy for daily activity. This is called aerobic activity. When you are fit, your heart will not have to work so hard. It will pump a lot fewer times per minute, reducing the wear and tear of your heart.

So as you can see, the fitter you are, the healthier and greater you will feel.

### Warm-up

Start each workout with 5 to 10 minutes of stretching and some light exercises. A proper warm-up increases your body temperature, heart rate and circulation in preparation for exercise. Ease into your exercise.



## Training Zone Exercise

After warming up, increase the intensity to your desired exercise program. Be sure to maintain your intensity for maximum performance. Breathe regularly and deeply as you exercise-never hold your breath.

## Cool Down

Finish each workout with a light jog or walk for at least 1 minute. Then complete 5 to 10 minutes of stretching to cool down. This will increase the flexibility of your muscles and will help prevent post-exercise problems.

## Workout Guidelines

### TARGET ZONE

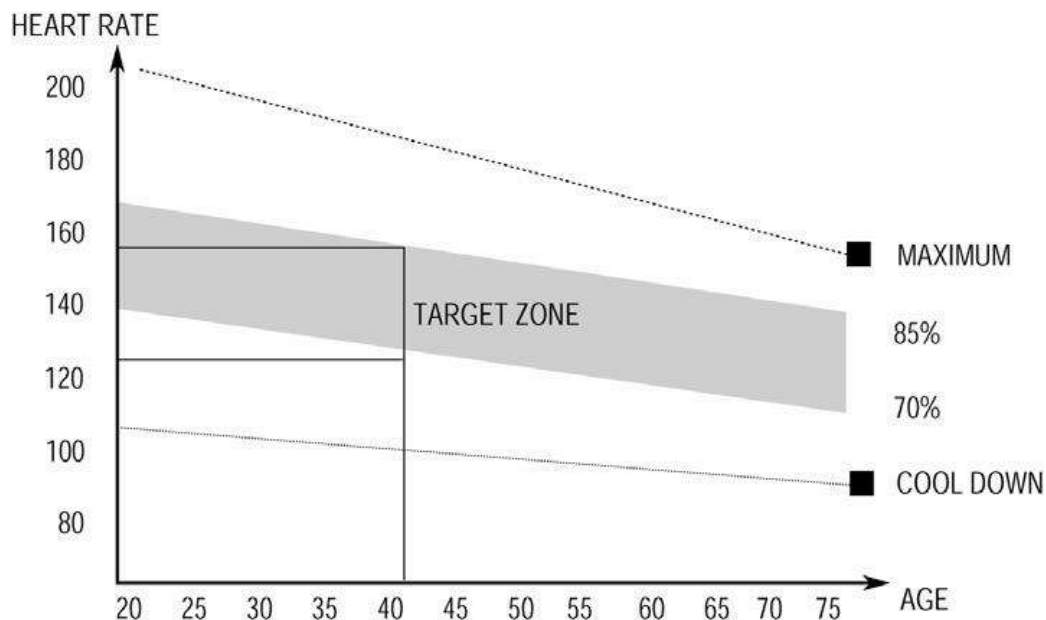

**THIS IS HOW YOUR PULSE SHOULD BEHAVE DURING GENERAL FITNESS EXERCISE.**

**REMEMBER TO WARM UP AND COOL DOWN FOR A FEW MINUTES.**

The most important factor here is the amount of effort you put in. The harder and longer you work, the more calories you will burn. Effectively this is the same as if you were training to improve your fitness, the difference is the goal.

## 9. MAINTENANCE INSTRUCTIONS

Reasonable cleaning/lubricating should be made to extend the life time of this unit. Performance is maximized when the belt and mat are kept as clean as possible.

**WARNING: THE MAT/DECK FRICTION MAY PLAY A MAJOR ROLE IN THE FUNCTION AND LIFE OF YOUR TREADMILL AND THAT IS WHY WE RECOMMEND YOU CONSTANTLY LUBRICATE THIS FRICTION POINT TO PROLONG THE USEFUL LIFE OF YOUR TREADMILL. FAILING TO DO THIS MAY VOID YOUR WARRANTY.**

**WARNING: UNPLUG POWER CORD BEFORE MAINTENANCE**

**WARNING: STOP TREADMILL BEFORE FOLDING**

### 1. General Cleaning

- Use a soft, damp cloth to wipe the edge of the belt and the area between the belt edge and frame. A mild soap and water solution along with a nylon scrub brush will clean the top of the textured belt. This task should be done once a month. Allow to dry before using.
- On a monthly basis, vacuum underneath your treadmill to prevent dust build up. Once a year, you should remove the black motor shield and vacuum out dirt that may accumulate.

### 2. General Care

- Check parts for wear before use.
- Pay particular attention to the fixing knobs and make sure they are tight.
- Always replace the mat if worn and any other defective parts.

- If in doubt do not use the treadmill and contact our helpline.

TAKE CARE TO PROTECT CARPETS AND FLOOR in case of leakages. This product is a machine that contains moving parts which have been greased / lubricated and could leak.

### **3. Belt/Deck/Roller Lubrication**

The mat/deck friction may play a major role in the function and life of your treadmill and that is why we recommend you constantly lubricate this friction point to prolong the useful life of your treadmill. Lubrication is provided with this unit. You should apply lubrication after approximately the first 50 hours of operation. We recommend lubrication of the deck according to the following timetable:

- Light use (less than 3 hours per week) every 6 months
- Medium use (3-5 hours a week) every 3 months
- Heavy use (more than 5 hours per week) every 6-8 weeks

See below procedures for lubricating:

1. Use a soft, dry cloth to wipe the area between the belt and deck.
2. Spread lubricant onto the inside surface of belt and deck evenly (make sure the machine is turned off and power is disconnected).
3. Periodically lubricate the front and rear rollers to keep them at their peak performance. If the treadmill belt/deck/roller is kept reasonably clean it is possible to expect over 1200 hours before relubricating is necessary.

### **4. How to check the running mat for proper lubrication:**

1. Disconnect the main power supply.
2. Fold the treadmill up into the storage position.
3. Feel the underside surface of the running mat.

If the surface is slick when touched, then no further lubrication is needed.

If the surface is dry to the touch, apply a suitable silicone lubricant.

**We recommend that you use a silicone based spray to lubricate your Lifespan treadmill. This can be purchased directly from us or any hardware store.**

## 5. Belt Tension Adjustment

It is very important for joggers and runners in order to provide a smooth, steady running surface. Adjustment must be made from the right and left rear roller in order to adjust tension with the Allen Key provided in the parts package. The adjustment bolt is located at the end of the rails as noted in the diagram below:

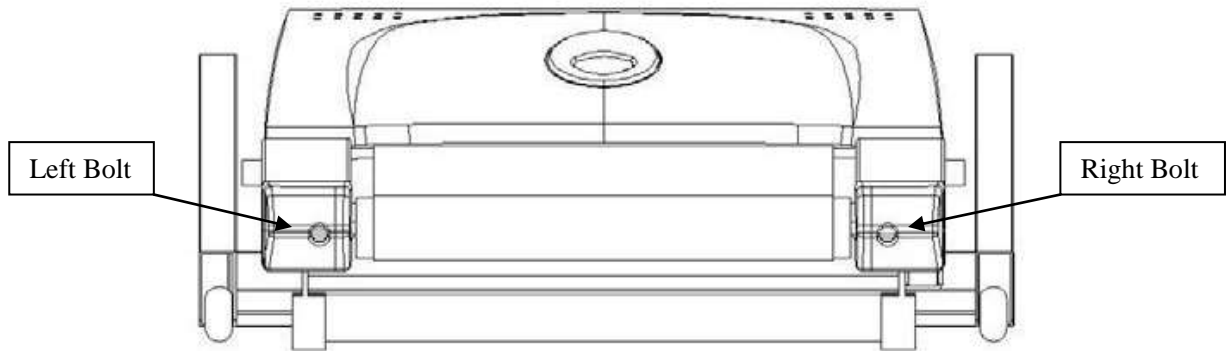

**Note: Adjustment is through small hold of end cap.**

Tighten the rear roller only enough to prevent slippage at the front roller. Turn both the right and left bolt clockwise one full turn and inspect for proper tension. When an adjustment is made to the belt tension, you must also make a tracking adjustment to compensate for the change in belt tension.

**DO NOT OVER TIGHTEN** - Over tightening will cause belt damage and premature bearing failure.

This may also cause reduced motor performance and excessive roller wear.

**NOTE:** When properly tightened, the sides of the belt can be raised approximately 2-3 inches off the board.

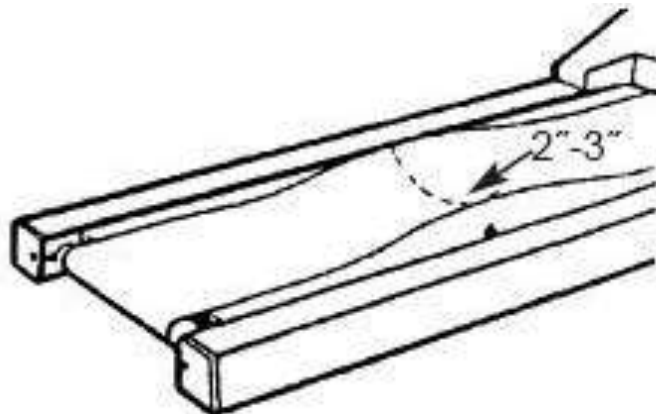

## 6. Belt Tracking Adjustment:

This treadmill is designed to keep the belt reasonably centred while in use. It is normal for some belts to drift near one side while the belt is running with no one on it. After a few minutes of use, the belt should have a tendency to centre itself. If during use, the belt continues to move toward one side, adjustments are necessary. The procedures are below:

1. Set speed at approximately 3.5km/h.
2. Check the side the belt shifts to.

If the belt shifts to right, tighten the right bolt and loosen the left bolt by using 6mm Allen Key, until the belt is centred itself; If belt shifts to left, tighten the left bolt and loosen the right bolt by using a 6mm Allen Key, until the belt is centred. When adjusting the belt using the 6 mm Allen Key, it is important to adjust the belt in half turn increments. Over adjusting the belt can cause damage to the mat.

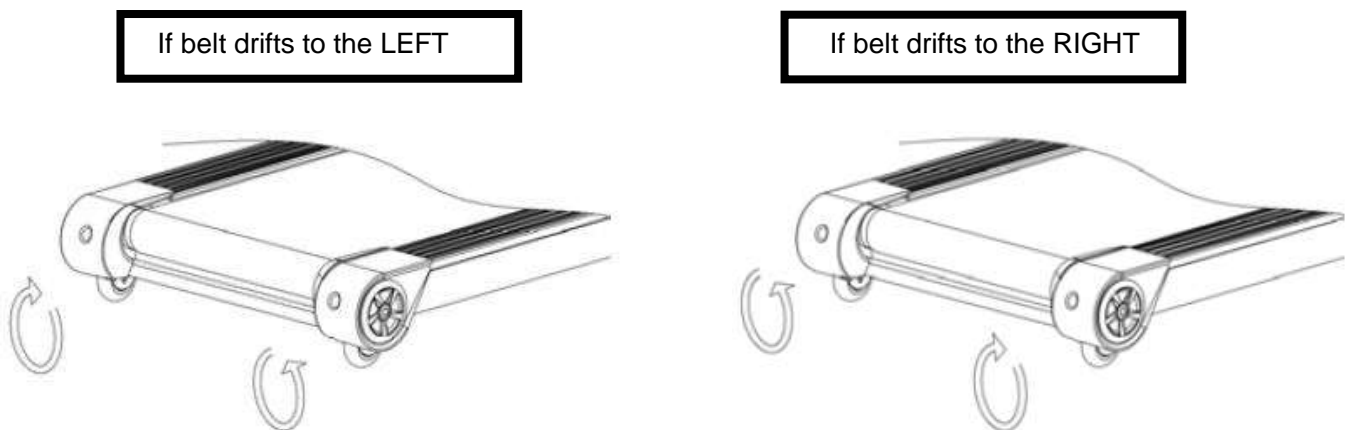

# 10. EXPLODED DIAGRAM

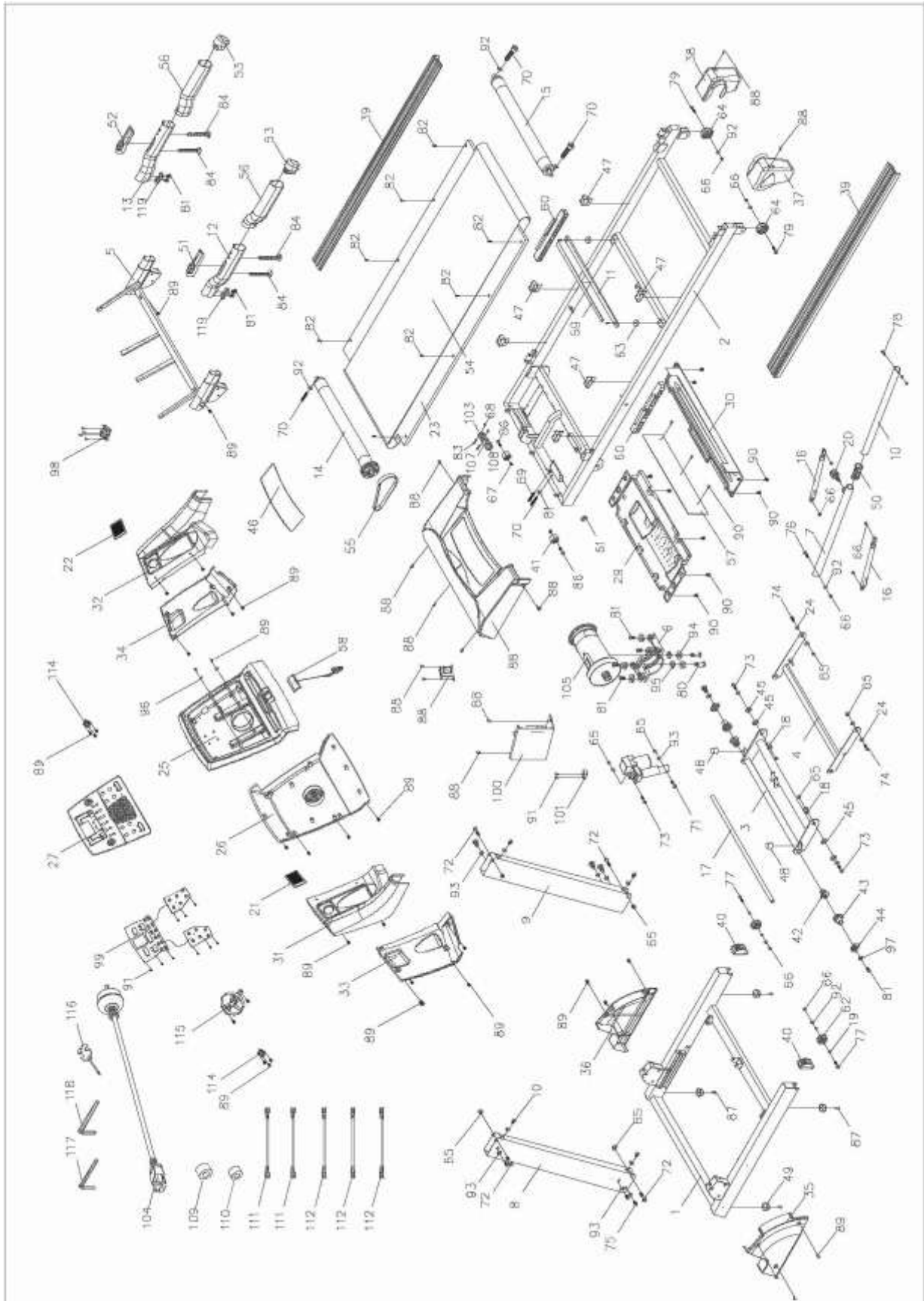

# 11. PARTS LIST

#.	DESCRIPTION	REMARK	QTY	#.	DESCRIPTION	REMARK	QTY
1	Base Frame		1	38	Right Back End Cover		1
2	Main Frame		1	39	Side Rail		2
3	Incline Bracket		1	40	Transport Wheel Plug		2
4	Support Bracket		1	41	Transport Wheel		2
5	Computer Bracket		1	42	Inner End Cap		2
6	Motor Bracket		1	43	Plastic Bearing		2
7	Conditioning Casing Components		1	44	Slider		2
8	Left Upright Tube		1	45	Plastic Pad		4
9	Right Upright Tube		1	46	Acrylic		1
10	Adjusting Inner Tube		1	47	Cushion		6
11	Running board strengthen tube		1	48	Cone Cushion		2
12	Left Handle Bar		1	49	Flat Foot Pad		4
13	Right Handle Bar		1	50	Adjust Inner Cashing Handle Pulse with Incline		1
14	Front Roller		1	51	Handle Pulse with Speed		1
15	Rear Roller		1	52	Oval Cashing		1
16	Cylinder		2	53	Running Belt		2
17	Slide Shaft		1	54	Motor Belt		1
18	axle sleeve with oil		2	55	Foam Grip		1
19	Pipe Plug Casing		4	56	Baffle		2
20	Spring Pin		1	57	Safety Key		1
21	Left Speaker Net		1	58	EVA Pad		1
22	Right Speaker Net		1	59	Cushion Pad Components		1
23	Running Board		1	60	Ring Wire Plug		2
24	Incline Turning Bushing		2	61	Transport Wheel		2
25	Computer Top Cover		1	62	Blue Cushion		2
26	Computer Bottom Cover		1	63	Adjust Wheel		2
27	Computer Panel		1	64	Lock Nut	M10	2
28	Motor Top cover		1	65	Lock Nut	M8	10
29	Motor Bottom Cover		1	66	Lock Nut	M8	10

30	Bottom Cover		1	67	Lock Nut	M5	2
31	Left Handle Bar Cover		1	68	Nut	M3	2
32	Right Handle Bar Cover		1	69	Bolt	M8*55	1
33	Left Computer Bottom Cover		1	70	Bolt	M8*60	4
34	Right Computer Bottom Cover		1	71	Bolt	M10*55 L20	1
35	Left Upright Tube Cover		1	72	Bolt	M10*50 L15	4
36	Right Upright Tube Cover	s	1	73	Bolt	M10*40 L15	3
37	Left Back End Cover		1	74	Bolt	M10*25	2
75	Bolt	M10*12	10	111	AC Single Wire		2
76	Bolt	M8*55 L20	1	112	AC Single Wire		3
77	Bolt	M8*50 L20	2	113	ground wire		1
78	Bolt	M8*45 L20	1	114	Speaker	Optional	2
79	Bolt	M8*40 L20	2	115	Fan	Optional	1
80	Bolt	M8*25 L15	2	116	Wrench s/screw Driver	S=13, 14、15	1
81	Bolt	M8*15	10	117	5# Allen Wrench	5mm	1
82	Bolt	M6*25	10	118	6# Allen Wrench	6mm	1
83	Bolt	M3*10	2	119	Arc Washer	Φ8	4
84	Screw	ST4.2*65(Φ8)	4	120			
85	Screw	ST4.2*20	4	121			
86	Bolt	M5*38 L20	2	122			
87	Bolt	M5*16	6	123			
88	Bolt	M5*8 (Φ9)	10	124			
89	Screw	ST4.2*12	27	125			
90	Screw	ST4.2*12(Φ8)	22	126			
91	Screw	S T2.9*6.5	38	127			
92	Lock Washer	GB861.2-87 Φ8	9	128			
93	Lock Washer	GB861.2-87 Φ10	16	129			
94	Lock Washer	GB/T93-1987 Φ8	6	130			
95	Flat Washer	GB/ T 95-2002 8	6	131			
96	Flat Washer	GB/T 95-2002 5	4	132			
97	Big Flat Washer	φ8*φ22*2.0	3	133			
98	Amplifier Board	optional	1	134			
99	Computer Board		1	135			

100	Control Board		1	136			
101	Magnetic Sensor		1	137			
102	Transformer		1	138			
103	Power Socket		1	139			
104	Power Wire		1	140			
105	DC Motor		1	141			
106	Incline Motor		1	142			
107	Square Shape Switch		1	143			
108	Overload Protect		1	144			
109	Magnetic Ring		1	145			

## 12. TROUBLE SHOOTING GUIDE

Error/Code	Description	Possible Solutions
	Computer not functioning after connecting power	<ol style="list-style-type: none"> <li>1. Please check if the overload protect jump, if it has, please press it, let it continue operation.</li> <li>2. Ensure the wires of the power switch, overload protection, control board and the transformer are connected correctly.</li> <li>3. Ensure the wire from the computer to the control board is connected properly. Remove the upright tube and check the connection between each wire. Ensure each wire is completely plugged in; if wires are damaged please change the wire.</li> <li>4. Check the state of the transformer is good, if broken, change it.</li> </ol>
E01	Message failure	<ol style="list-style-type: none"> <li>1. The wires from computer and bottom control board are not properly connected, please check each wire. If the wire was destroyed replace it.</li> <li>2. Check the state of the transformer is good, if broken, change it.</li> </ol>
E02	Burst clash	<ol style="list-style-type: none"> <li>1. Ensure power is correct, if not, use correct power to test.</li> <li>2. Check if the bottom control is burnt out, if burnt out replace it and then reconnect the motor wire.</li> </ol>
E03	No sensor signal	<ol style="list-style-type: none"> <li>1. The sensor signal was not detected within 10 seconds. Check the sensor plug connection</li> <li>2. See if the magnetic sensor is broken or damaged, re-connect the plug well or change the sensor.</li> </ol>

E04 or E06	Incline learning defeated	<ol style="list-style-type: none"> <li>1. Check connection of VR wire of incline motor. If improperly connected, reconnect VR and make it firm.</li> <li>2. Check to see if AC wire of motor is properly connected, and if the AC wire of the motor is inserted properly with correct sign on control board.</li> <li>3. Check connection line of motor to see if it is destroyed, exchange it or incline motor. And press “learning” button of bottom control board to relearn upon completion of checks.</li> </ol>
E05	Overload protection	<ol style="list-style-type: none"> <li>1. Upon overload, the system will restart to prevent damage. If the treadmill gets stuck and the motor cannot move it will lead to an overload. Please locate the cause of this. A possible reason is a lack of lubricant in a particular component. Then restart the machine.</li> <li>2. Check if the motor sounds like its being over worked or for a burning smell. If so, change motor</li> <li>3. Check control board. If control board is emitting a burning smell, change it.</li> </ol>
E07	No signal between the control board and computer	<ol style="list-style-type: none"> <li>1. The wires from computer and bottom control board are not properly connected, please check each wire. If the wire is destroyed replace it.</li> <li>2. Ensure wires of control board are properly connected, replace any broken parts on the board</li> <li>3. Replace transformer</li> </ol>
E08	Control board problem	<ol style="list-style-type: none"> <li>1. Replace controller</li> </ol>
E09	Machine is folded	<ol style="list-style-type: none"> <li>1. Ensure that the machine is correctly unfolded, restart.</li> <li>2. Replace transformer</li> </ol>

	<p>Motor not functioning after pressing START button</p>	<ol style="list-style-type: none"> <li>1. the motor wire is broken; the safety pipe is broken or has fallen off;</li> <li>2. motor wire is not properly connected</li> <li>3. IGBT on bottom control board is burnt out. Test the above reasons and change the relevant part.</li> </ol>
--	--	--

## 13. WARRANTY

### AUSTRALIAN CONSUMER LAW

*Many of our products come with a guarantee or warranty from the manufacturer. In addition, they come with guarantees that cannot be excluded under the Australian Consumer Law. You are entitled to a replacement or refund for a major failure and compensation for any other reasonably foreseeable loss or damage.*

*You are entitled to have the goods repaired or replaced if the goods fail to be of acceptable quality and the failure does not amount to a major failure. Full details of your consumer rights may be found at [www.consumerlaw.gov.au](http://www.consumerlaw.gov.au)*

Please visit our website to view our full warranty terms and conditions:

<http://www.lifespanonline.com.au/Warranty-Policy>