

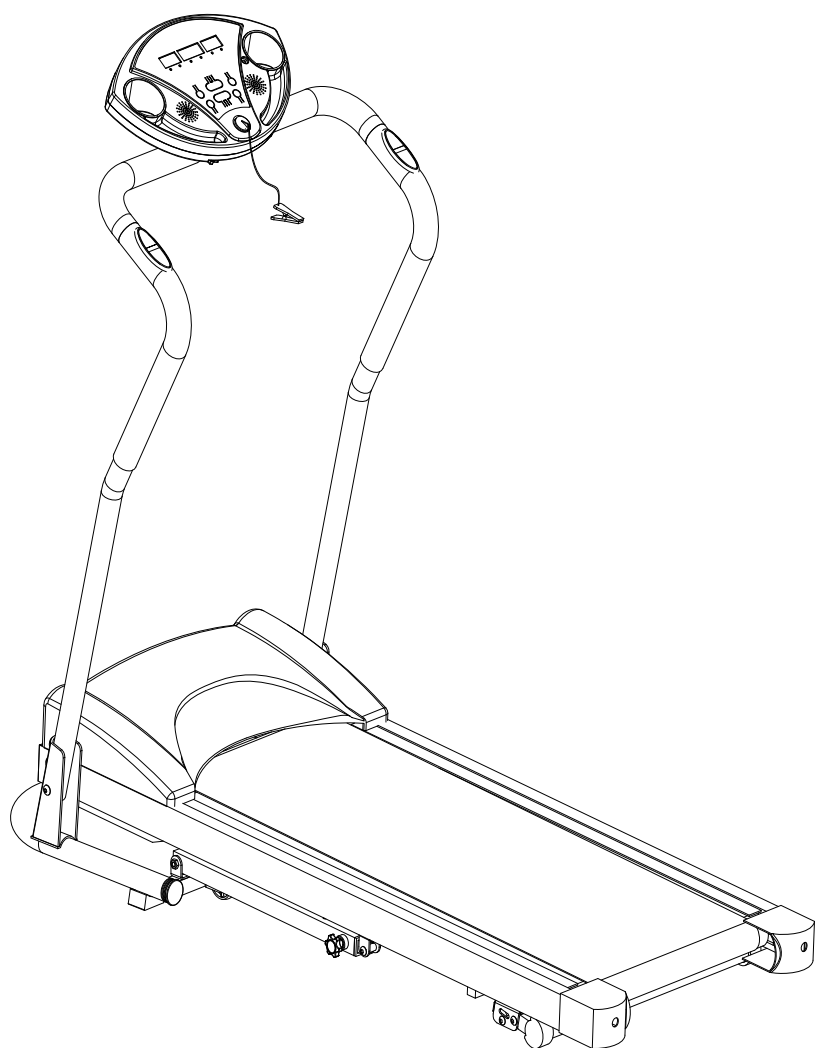

**BOOMER  
PLUS**  
*USER'S  
MANUAL*



This is HIGH-POWER item; please DO NOT USE THE SAME OUTLET WITH OTHER HIGH-POWER HOUSEHOLD APPLIANCE like air-conditioning etc.  
Please choose an outlet exclusively for the machine and make sure the fuse is 10A.

**Product may vary slightly from the item pictured due to model upgrades**

## **IMPORTANT SAFETY PRECAUTIONS**

**CAUTION:** Before starting any exercise program, consult with your physician or health professional.

**IMPORTANT:** Read all instructions carefully before using this product. Retain this owner's manual for the future reference.

1. Plug the power cord of the treadmill directly into a dedicated grounded circuit.  
This product must be grounded well. If it has breakdown, grounding provides a path of least resistance for electric current to reduce the risk of electric shock.
2. Position the treadmill on a clear and level surface. Do not place the treadmill on thick carpet as it may interfere with proper ventilation. Also, do not place the treadmill near water or outdoors.
3. Position treadmill so that the wall plug is visible and accessible.
4. **NEVER** start the treadmill while you are standing on the walking belt. After turning the power on and adjusting the speed control, there may be a pause before the walking belt begins to move, **ALWAYS** stand on the foot rails on the sides of the frame until the belt is moving.
5. Wear appropriate clothing when exercising on the treadmill. Do not wear long, loose fitting clothing which maybe caught by treadmill. Always wear running or aerobic shoes with rubber soles.
6. Always unplug the power cord before removing the treadmill's motor cover.
7. Keep small children away from the treadmill during operation.
8. Don't let go of your hands until you are getting used to treadmill's waking or running.
9. If you want to stop the exercise or the Treadmill suddenly increases in speed due to an electronics failure, please make sure to put your hands on the both uprights firstly, and then step on the ride rail to avoid the damage by moving running belt.
10. Always attach the safety key rope to your clothing when using the treadmill. If the treadmill suddenly increases in speed due to an electronics failure or the speed being inadvertently increased, the treadmill will come to a sudden stop when the safety key is disengaged from the console. Pull off the safety key and keep it well when you do not use the machine.
11. When the treadmill is not being used, the power cord should be unplugged and the safety key should be removed.
12. Before starting any exercise program, consult with your physician or health professional. He or she can help you to establish the exercise frequency, intensity (target heart zone) and time appropriate to your particular age and physical condition. If you have any pain or tightness in your chest, an irregular heartbeat, shortness of breath, feel faint or any discomfort while you exercise,

**STOP IMMEDIATELY!** Consult your physician before continuing.

**13.** If you observe any damage or wear on the mains plug or on any section of the mains lead then please have these replaced immediately by a qualified electrician – do not attempt to change or repair these yourself.

**14.** When the treadmill is not being used, please pull out the safety lock and store up it in order to prevent the children and other people from incorrectly using of the treadmill.

**15.** The pulse sensors are not medical devices. Various factors, including the user's movement, may affect the accuracy of heart rate readings. The pulse sensors are intended only as exercise aids in determining heart rate trends in general.

**For your information, please note following electronical specification of Treadmill:**

a. The input voltage:  $240V \pm 10\%$  (50-60HZ)

b. Input current:  $\leq 6A$

c. The rating power: 1.5HP

d. Time Range: 0:00-99:99

e. Speed Range: 0.8-16.00KM/H

f. Distance Range: 0.00-99.9KM

g. Calories range: 0-999CAL

h. Pulse range: 40-165times/ minute

## **IMPORTANT OPERATION INSTRUCTIONS**

- Be sure to read the entire manual before operating your machine.
- Understand that changes in speed and incline do not occur immediately. Set your desired speed on the computer console and release the adjustment key. The computer will obey the command gradually.
- Use caution while participating in other activities while walking on your treadmill; such as watching television, reading, etc. These distractions may cause you lose balance or stray from walking in the centre of the belt; which may result in serious injury.
- In order to prevent losing balance and unexpected injury, NEVER mount or dismount the treadmill while the belt is moving. This unit starts at a very low speed. Simply standing on the belt during slow acceleration is proper before you have learned to operate this machine.
- Always hold on to handrail while making control changes.

- A safety key is provided with this machine. Remove the safety key will stop the walking belt immediately; the treadmill will shut off automatically. Insert the safety key will reset the display.
- Do not use excessive pressure on console control keys. They are precision set to function properly with little finger pressure.

## **FOLDING INSTRUCTIONS**

When folding the treadmill, pull out the handles on the holding spanner and place the main frame at corresponding position. By then, the handle bolt will appear automatically. After that, move the treadmill to another place so as to make it occupy a smaller area. Before usage, place the treadmill to the position you would like to do exercise, and lift its main frame by right hand and pull out the handles and place them on the floor slowly. Then the handles will appear automatically. Finally screw down the handles firmly to release yourself from being worried about the safety during exercise.

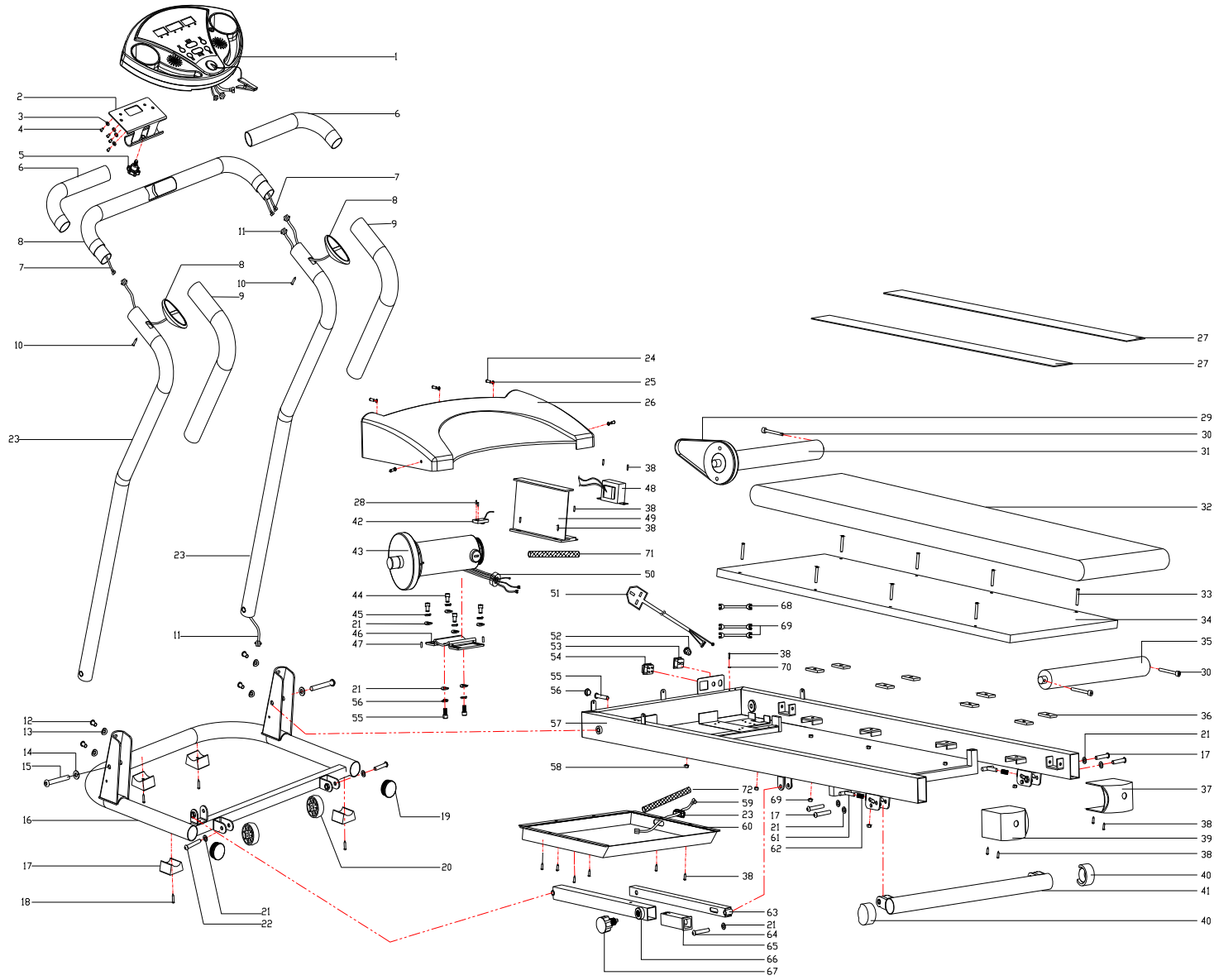

## PARTS LIST







#	Name.	Specification	NR.
1	Computer	See the program	1
2	Alloy cover	See the program	1
3	Flat washer	D4	4
4	Cross pan-headed bolt	M4×12	4
5	M8 knob	See the program	1
6	Foam grips	Φ36×3×375	2
7	Trunk line1		2
8	Tube		1
9	Foam column	Φ36×3×375	2
10	Cross pan-headed bolt	ST3.5×30	2
11	Trunk line2		1
12	Inner hexagonal pan-headed bolt	M10×20	4
13	washer	D10	4
14	Flat washer	D10	2
15	Inner hexagonal pan-headed bolt	M10×65	2
16	Base combined		1
17	washer		4
18	Cross pan-headed bolt	ST4.2×20	4
19	Round caps	Φ38	2
20	Running wheel	Φ50×Φ8.2×22	2
21	Flat washer	D8	10
22	Inner hexagonal pan-headed bolt	M8×45	2
23	Sleeve		1
24	Cross pan-headed bolt	M5×12	5
25	Flat washer	D5	5
26	Motor cover(up)		1
27	Foot rail	63×1070	2
28	Cross pan-headed bolt	ST4.2×15 head Φ6	2
29	Belt	180J6	1
30	Inner hexagonal bolt	M6×60 S5	3
31	Front roller		1

#	Name.	Specification	NR.
38	Cross pan-headed bolt	ST4.2×15	17
39	Bowl cover		1
40	Semicircle knot	Φ38	2
41	Tube combine		1
42	Square magnet		1
43	Motor	1.5HP	1
44	Inner hexagonal pan-headed bolt	M8×15	6
45	Sprint pin	D8	6
46	Alloy cover		1
47	Adjustable pin	Φ5×1×12	2
48	Transformer		1
49	Control board		1
50	Magnetic ring	Φ25×Φ15×12	1
51	Current wire	Length 2060mm	1
52	Current wire clasp	6N-4	1
53	Protector		1
54	Switch	KCD4	1
55	Inner hexagonal bolt	M8×35	1
56	Sleeve		1
57	Combination		1
58	Nylon bolt	M6	8
59	Trunk line3	Length 300	1
60	Motor cover(down)		1
61	Detent pin		2
62	pin		1
63	Tube combination		1
64	Inner hexagonal bolt	M8×40	1
65	Hollow bush		1
66	Tube combination		1

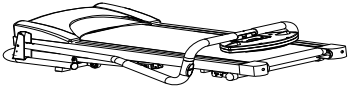
#	Name.	Specification	NR.
32	Running belt	2494×400×1.6	1
33	Inner hexagonal sunk-headed bolt	M6×30 S4	8
34	Running board	1085×486×15	1
35	Rear roller		1
36	Cashion running board	30×40×5	8
37	Bowl cover		1

#	Name.	Specification	NR.
67	Degree adjustable pin	M16	1
68	Blue connection wire		1
69	Red connection wire		2
70	Stop washer	D5	1
71	Nylon tube	Length 200mm	1
72	Wax tube	Length 200mm	1

### Assembly parts list:

		
I	II	III
		
IV	V	VI
		
VII		

### Hardware Contains:

Parts#	Description	Remarks	Qty.
I	Main frame		1
II	M8 knob		1
III	Degree adjustable pin t		1

**TOOLS AND NUTS LIST:**

Part No.	Name	Specification	Numbers
IV	Inner hexagonal wrench	S6	1
V	Inner hexagonal wrench	S5	1
VI	Inner hexagonal wrench	S4	1
VII	Cross-head wrench	S13, S14, S15	1

## ASSEMBLY INSTRUCTIONS

1. Main frame and Support connection: Fix the Left support and Right support onto the Main frame tightly with inner hexagonal pan-headed bolt (13) and the spring washer (22).

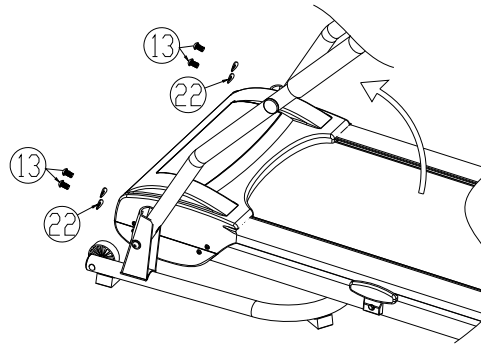

2. Fit the Table Block Associated onto the Left and Right support..

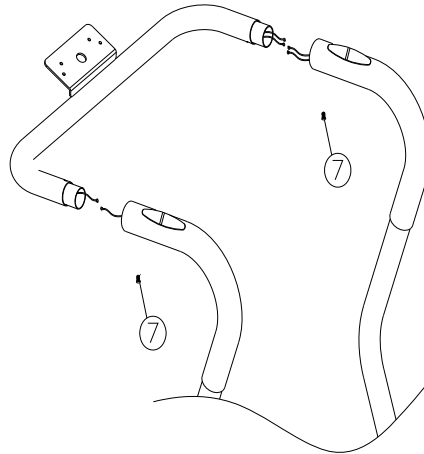

3. Take the computer(75) out from the carton, and fix it onto the Left and Right support with adjustable bolt(34).

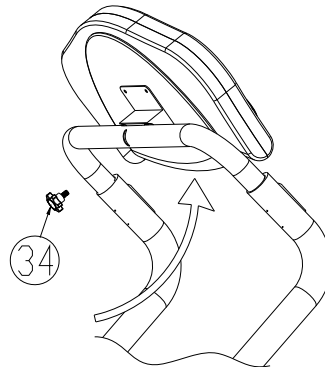

### CAUTION:

1. Do not plug in power cord until final assembly is completed and motor cover is installed.
2. Do not attempt to assemble the treadmill until the assembly instructions are followed and the uprights are attached to the treadmill. Failure to follow this can result in damage to the treadmill.
3. Your treadmill is a very heavy piece of exercise equipment and should be handled with caution.
4. Children should not be allowed to play on the treadmill or move the treadmill deck up and down.
5. We recommend you have someone to assist you in lifting and assembling your Lifespan treadmill. Following these instructions carefully which will make it's easier to assemble your Lifespan treadmill.
6. **Ensure all fixings are tightly secured and the treadmill is well constructed.**

# OPERATION GUIDE



C

## CONSOLE DISPLAYS, FEATURES AND FUNCTIONS:

Your treadmill comes with an innovative console designed to make your intense workout fun and entertaining. Below are the features and benefits of the console:

### —. Shown windows

#### **4 LED windows: SPEED, TIMR/DIST,PULSE, CALORIES and 3 Arc indicator light.**

1. Window SPEED: Displays the current speed. Speed Range: 0.8~16.00KM/H

2. Window PULSE: Displays the current heart rate. Pulse Range: 45~160 bpm. To use the handgrip pulse sensor, firstly remove the films of clear plastic from the metal contacts on the handgrip pulse sensor. Next, stand on the foot rails and hold the metal contacts with your hands. Don't move and shift your hands. When pulse is detected, your heart rate will appear in the display. For the most accurate heart rate reading, continue to hold the contacts for about 15 seconds. (For an official medical reading, please consult a physician).

3. Window time/dist: Displays the current time and running distance. The corresponding indicator light is on and the window displays time and distance separately every 5 seconds when the machine is default and working; The windows show programs No. when the program is being setting, the windows show 3 seconds counting down, 3—2—1.

4. Windows calories: Displays dissipative calories. The calories range is 0.00-999.9Cal.

The window shows "0" if you waste the calories more than 999.9 cal and count on sequentially. When you count down, the calorie is from "setting cal" to "0".

5.Arc speed indicator light: The corresponding indicate is red when you reach to this speed.

6.Arc pulse indicator light: The light "0" is on when it is pending; the light "30" is on when the pulse is  $\leq$  "45 times/seconds"; the light "60" is on when the pulse is  $>$  "45 times/seconds" and  $\leq$  "75times/seconds";All the lights will be on when the pulse is  $>$  "165times/seconds" by this way.

7. Arc calories indicator light: The light "50" is on when the amount is  $\leq 75$  cal; The light "150" is on when the amount is  $>75$  cal and  $\leq 150$  cal; All the lights is on when the amount is  $>900$  cal.

## 二. Button operations

### 1. START/ STOP

Press the button to start or stop the treadmill. When in Manual Mode, the treadmill will start moving at the minimum speed. In the preset programs, it will start moving from the last speed and the windows TIME/DIST,PULSE,CALROES will begin to count up.

### 2. SPEED (+) or (-)

a. To set the speed, press the speed button until the desired speed shows on the display.  
b. Increase or Decrease speed as desired while running by pressing the Speed (+) or (-). Speed will increase or decrease 0.1km/h increments. When speed reaches 16.00km/h, pressing SPEED(+) will no longer increase the speed. When speed reaches 0.8km/h, pressing SPEED(-) will no longer decrease the speed. Holding the SPEED (+) or (-), for 1/2 second, the speed will increase or decrease rapidly

### 3. PROGRAM MODE

a. Press PROGRAM button to choose program among P01 ~P24  
b. Note that while running the Program button will not work

### 4. MODE

a. Insert Safety Key in and then press the DISPLAY button to choose the manual modes "0:00", counting down of time, distance or calories. And the related windows value will flash. Press SPEED (+) or (-) to adjust the related window value, then press "START" to start the treadmill.  
b. In RUNNING MODE, press the button to choose the speed diagram or incline diagram in the Race Track LED window.

## 三. START MODE (MANUAL MODE):

1. Press "START", the Race Track display will show a 3 seconds count down followed by a beep signal the running belt is starting to move. The treadmill will start at the speed of "0.8KM/H".  
2. Press "SPEED-/SPEED+" button on the console to increase/decrease the speed.

## 四. THE MANIPULATION DURING EXERCISE:

1. Press "SPEED+" to increase the running speed.  
2. Press "SPEED-" to decrease the running speed.  
3. Press "STOP" button to stop the machine working.  
4. The pulse windows will show your heart rate when you hold the hand pulse set more than 5 seconds.

## 五. MANUAL MODE

1. Insert the safety Key then press "START". The treadmill will start from the speed of 0.8 km/h at an incline of 0%. Press the "SPEED+", "SPEED-". For a quick jump to a speed level press the preset buttons.  
2. Insert the safety key then press the "DISPLAY MODE" button. The time will begin to count down. The TIME window will display flashing the number "30:00". Press the "SPEED+", "SPEED-" to set the value of time. Time can be set from 10:00 to 99:00.  
3. When the time is in the mode of counting down, press "DISPLAY MODE" and the distance will begin to count down. The DISTANCE window will display the flashing number "1.0". Press the "SPEED+", "SPEED-" to set the value of distance. Setting

value is from 0.5 to 99:9.

- When the distance is in the mode of counting down, press "DISPLAY MODE" and the calories will begin to count down. The CAL window will display the flashing number "50". Press the "SPEED+", "SPEED-" to set the desired distance. Setting value is from 10 to 999.
- After setting, press START, the treadmill will start after 3 seconds. Press the "SPEED+", "SPEED-" to change the incline and the speed. Press STOP to stop the treadmill.

## 六. EXERCISE IN INNER MODE

There are 24 manual mode P01-P24. Press "PROGRAM" button, the windows speed show "PRO", "TIME/DISTANCE" shows "P-XX", you can choose the mode by pressing "SPEED+" or "SPEED -" the mode is from P01 to P24. "TIME/DIST" window is on when you press "MODE" button. The presetting time is 30:00. You can set how long you will exercise by pressing "SPEED+" or "SPEED -". (Please press "MODE" button if you want to come back to manual program; press "PROGRAM" button if you want to exit). Press "START" button to start-up the manual program. They are shown 20 sections, exercising time is setting time/20. The systems will make the noise "Bi-Bi-Bi" when it enters the next section. The system speed will change according to the program's changing. You can press "SPEED+" or "SPEED -" to change the speed. The system will show the speed in this section when it enters the next section.

## 七. USER DEFINED PROGRAM

There are 3 User defined program: U-01,U-02,U-03 except 24 system manual programs

### 1. User's defined program:

Insert the safety key then press "START" two times into the user defined program. The window SPEED shows "PRO"; The windows TIME/DIST shows "U-XX", you can choose the mode by pressing "SPEED+" or "SPEED -". You can enter time setting by pressing "MODE" button after you choose your defined program. The windows TIME/DIST shows "30:00",you can choose your time by press "SPEED +"or "SPEED -". You can enter time setting in every section by press" MODE" button. The window TIME/DIST shows "U1.01",it shows that you have finished the first setting. The window SPEED shows default speed, then you can adjust to the speed in first section by pressing "SPEED +" or "SPEED -". After you finish the speed, then you press "MODE" button to enter the second section, the window "TIME/DIST" shows "U1.02". All the datas will be saved until you set again. These datas will save whether it is off or not.

## 八. PRESET PROGRAMS

It will display any of P01~P12 in the RACE TRACK LED window. You only need to preset the time. There are 20 intervals when running and the speed will change automatically. Refer the left-bottom charts in the panel.

## 九. RANGE OF PROGRAM

SETTING PARAMETER	BEGIN	SETTING BEGINING VALUE	SET UP RANGE	DISPLAY RANGE
TIME (MINUTE: SECOND)	0:00	30:00	10:00—99:00	0:00—99:99
SPEED	0.8	0.8	0.8—16.0KM/H	0.8—16.0KM/H
DISTANCE	0.00	1.0	0.5—99.9KM/MP	0.00—99.9KM/MP
HANDPULSE (TIMES/MINUTE)	P	N/A	N/A	40-165
CALORIES(THERM)	0	50	10—999	0—999

†. **SAFETY KEY FEATURE:**

The safety Key is designed to function as an emergency stop mechanism. For this reason it is extremely important for you that the safety key CORD should be attached to your clothing at all times while using the treadmill. As soon as the key is pulled out from the sensor, the treadmill will stop immediately. The Media center features and the fan may continue to work. But the treadmill will stop. Reinsert the safety key to start the treadmill again.

## **MAINTENANCE**

Reasonable cleaning/lubricating should be made to extend the life time of this unit. Performance is maximized when the belt and mat are kept as clean as possible.

**WARNING: THE MAT/DECK FRICTION MAY PLAY A MAJOR ROLE IN THE FUNCTION AND LIFE OF YOUR TREADMILL AND THAT IS WHY WE RECOMMEND YOU CONSTANTLY LUBRICATE THIS FRICTION POINT TO PROLONG THE USEFUL LIFE OF YOUR TREADMILL. FAILING TO DO THIS MAY VOID YOUR WARRANTY.**

**WARNING: UNPLUG POWER CORD BEFORE MAINTENANCE.**

**WARNING: STOP TREADMILL BEFORE FOLDING.**

# 1 Maintenance and servicing

## ***AFTER EACH USE (DAILY)***

Clean and inspect, following these steps:

- Turn off the treadmill with the on/off switch, then unplug the power cord at the wall outlet.
- Wipe down the running belt, deck, motor cover, and console casing with a damp cloth. Never use solvents, as they can cause damage to the treadmill.
- Inspect the power cord. If the power cord is damaged, contact Lifespan Fitness.
- Make sure the power cord is not underneath the treadmill or in any other area where it can become pinched or cut.
- Check the tension and alignment of the running belt. Make sure that the treadmill belt will not damage any other components on the treadmill by being misaligned.

## ***EVERY WEEK***

Clean underneath the treadmill, following these steps:

- Turn off the treadmill with the on/off switch, then unplug the power cord at the wall outlet.
- Fold the treadmill into the upright position, and make sure that the lock latch is secure.
- Move the treadmill to a remote location.
- Wipe or vacuum any dust particles or other objects that may have accumulated underneath the treadmill.
- Return the treadmill to its previous position.

## ***EVERY MONTH -IMPORTANT!***

- Inspect all assembly bolts of the machine for proper tightness.
- Turn off the treadmill with the on/off switch, then unplug the power cord and wait 60 seconds.
- Remove the motor cover. Wait until ALL LED lights turn off.
- Clean the motor and lower board area to eliminate any lint or dust particles that may have accumulated. Failure to do so may result in premature failure of key electrical components.

## ***EVERY 6 MONTHS***

It may be necessary to lubricate your treadmill running deck at least once every six months to maintain optimal performance of your treadmill (refer to section 4.4 for information). Only use lubricant provided by Lifespan Fitness! Please contact Lifespan Fitness with questions about applying lubricant to your treadmill.

- Turn off the treadmill with the on/off switch, then unplug the power cord at the wall outlet.
- Loosen both side of rear roller bolts. (For best results, place two removable marks on both sides of the

frame and note roller position). Once the belt is loosened, take the bottle of lubricant and apply it to the entire top surface of the running deck. Tighten both rear roller bolts (matching up the marks for proper position) to original position. After you have applied lubricant, plug in the power cord, key, start the treadmill and walk on the belt for two minutes to spread the lubricant.

- Lubricate the air shocks with Teflon based spray.

**SERVICING: IF YOU FAIL TO COMPLY WITH LIFESPAN'S MAINTENANCE AND SERVICING STEPS ABOVE, YOU MAY VOID YOUR WARRANTY. IF YOU REQUIRE A SKILLED LIFESPAN REPRESENTATIVE TO UNDERTAKE ONE OF THE STEPS ABOVE, PLEASE EMAIL US AT [lifespanfitness@hotmail.com](mailto:lifespanfitness@hotmail.com).**

## 2 General Cleaning

- Use a soft, damp cloth to wipe the edge of the belt and the area between the belt edge and frame. A mild soap and water solution along with a nylon scrub brush will clean the top of the textured belt. This task should be done once a month. Allow to dry before using.
- On a monthly basis, vacuum underneath your treadmill to prevent dust build up. Once a year, you should remove the black motor shield and vacuum out dirt that may accumulate.

## 3 General Care

- Check parts for wear before use.
- Pay particular attention to the fixing knobs and make sure they are tight.
- Always replace the mat if worn and any other defective parts.
- If in doubt do not use the treadmill and contact our helpline.

TAKE CARE TO PROTECT CARPETS AND FLOOR in case of leakages. This product is a machine that contains moving parts which have been greased / lubricated and could leak.

## 4 Belt/Deck/Roller Lubrication:

The mat/deck friction may play a major role in the function and life of your treadmill and that is why we recommend you constantly lubricate this friction point to prolong the useful life of your treadmill.

Lubrication is provided with this unit. You should apply the enclosed lubrication after approximately the first 50 hours of operation. We recommend lubrication of the deck according to the following timetable:

Light use (less than 3 hours per week) every 6 months

Medium use (3-5 hours a week) every 3 months

Heavy use (more than 5 hours per week) every 6-8 weeks.

See below procedures for lubricating:

1. Use a soft, dry cloth to wipe the area between the belt and deck.
2. Spread lubricant onto the inside surface of belt and deck evenly (make sure the machine is turned off and power is disconnected).
3. Periodically lubricate the front and rear rollers to keep them at their peak performance.

If the treadmill belt/deck/roller is kept reasonably clean it is possible to expect over 1200 hours before additional re-lubing is necessary.

## 5 How to check the running mat for proper lubrication:

1. Disconnect the main power supply.
2. Fold the treadmill up into the storage position.
3. Feel the back surface of the running mat.

If the surface is slick when touched, then no further lubrication is needed.

If the surface is dry when touched, apply a suitable silicone lubricant.

**We recommend you use a silicone based spray to lubricate your Lifespan Treadmill. This can be purchased from your local sports Retailer or a local hardware store.**

## 6 Belt Adjustment

Belt Tension Adjustment-It is very important for joggers and runners in order to provide a smooth, steady running surface. Adjustment must be made from the right and left rear roller in order to adjust tension with the Hexagonal Wrench provided in the parts package. The adjustment bolt is located at the end of the rails as noted in diagram below:



**Note: Adjustment is thru the small hold on the end caps.**

Tighten the rear roller only enough to prevent slippage at the front roller. Turn both the right and left bolt clockwise reasonably and inspect for proper tension. When an adjustment is made to the belt tension, you must also make a tracking adjustment to compensate for the change in belt tension.

**DO NOT OVERTIGHTEN** - Over tightening will cause belt damage and premature bearing failure.

## 7 Belt Tracking Adjustment:

This treadmill is designed to keep the belt reasonably centred while in use. It is normal for some belts to drift near one side while the belt is running with no one on it. After a few minutes of use, the belt should have a tendency to centre itself. If during use, the belt continues to move toward one side, adjustments are necessary. The procedures are as below:

▲ first set speed at lowest position.

▲ second check the belt shifts to which side.

If the belt shifts to right, tighten the right bolt and loosen the left bolt by using 6mm Hexagonal Wrench, until the belt is centered itself; If belt shifts to left, tighten the left bolt and loosen the right bolt by using 6mm Hexagonal Wrench, until the belt is centered. When adjusting the belt using the 6 mm Hexagonal Wrenches, it is important to adjust the belt in half turn increments. Over adjusting the belt can cause damage to the mat.

## 8. Solutions for Failure Elimination

Failure	Possible Reason	Solution
The power supply is connected and the electric running machine has started, however, there is no any display.	1 . The socket and power supply is not connected well. 2 . The socket of electric motor is not connected well. 3 . The fuse is burned.	1. Insert the socket again. 2. Re-connect the socket. 3. Disconnect the power supply and replace the fuse.
All displays fail to work.	Keys are installed improperly in emergency.	Perfect the installation.
Operation stops automatically and E1 is displayed.	The self-maintenance function of system works suddenly.	1 . Restart the electric running machine after pressing 'STOP'. 2 . Restart the electric running machine after the power supply has been disconnected for 5min. 3. Replace the sensor.
Display shows a normal operation, the strap, however, operates improperly and suffers from a cacophony.	The input voltage is too low.	The input power should meet the requirement.
The electric running machine operates normally with no load but halts midway.	The strap becomes loose.	Adjust the strap following the specification.
The display fails to work or cannot display at all, and the keys don't work.	The electronic meter is influenced by an external factor.	Disconnect the power supply and switch off switches, and restart the electric running machine 5min later.

# WARRANTY REGISTRATION

Please visit the following link to complete the product warranty form online. Please visit <http://warrantyform.lifespanfitness.com.au/>

**PLEASE NOTE: YOUR WARRANTY IS ONLY VALID IF YOU CAN PROVE YOU ARE THE ORIGINAL PURCHASER ON THIS ITEM (i.e. a copy of the receipt, invoice, delivery date or internet confirmation).**